

Have already passed ISO9001:2000 authentication

Children's electronic toy car

Operation instructions

Please read a manual in detail before using



Products about us.....

Thank you for your purchasing our products, we always keep pursuing being outstanding and designing comfortable and safe children and riding and riding toys constantly. It will give your child a wonderful childhood, and give your family lots of happiness.

Before use, read this "Operation Instructions" carefully to get correct operation method, simple and easy installation procedure; It still can instruct you how to prevent improper operation from damaging a product or injuring children. The very important one is it still can tell you a lot of safe precautions. Please learn this content by heart, guide your child's use; Please keep manual properly, put on easy to take office their.

Specification of this car.....

Suitable age:	3-6years old	Use the temperature range:	0° -40° C
Limited weight:	Less than 30kgs	External dimension (after assembling):	108x67x76.5cm
Speed:	3-5/HR	Power way:	charging type
Charge: Input:	Depend on local voltage Output: DC 6v/12v	Battery:	Sealed and dried battery 1x6V10AH/1x12V10AH
Charge time:	8-12HR	Life of battery:	300 times approximately

Install the part table.....

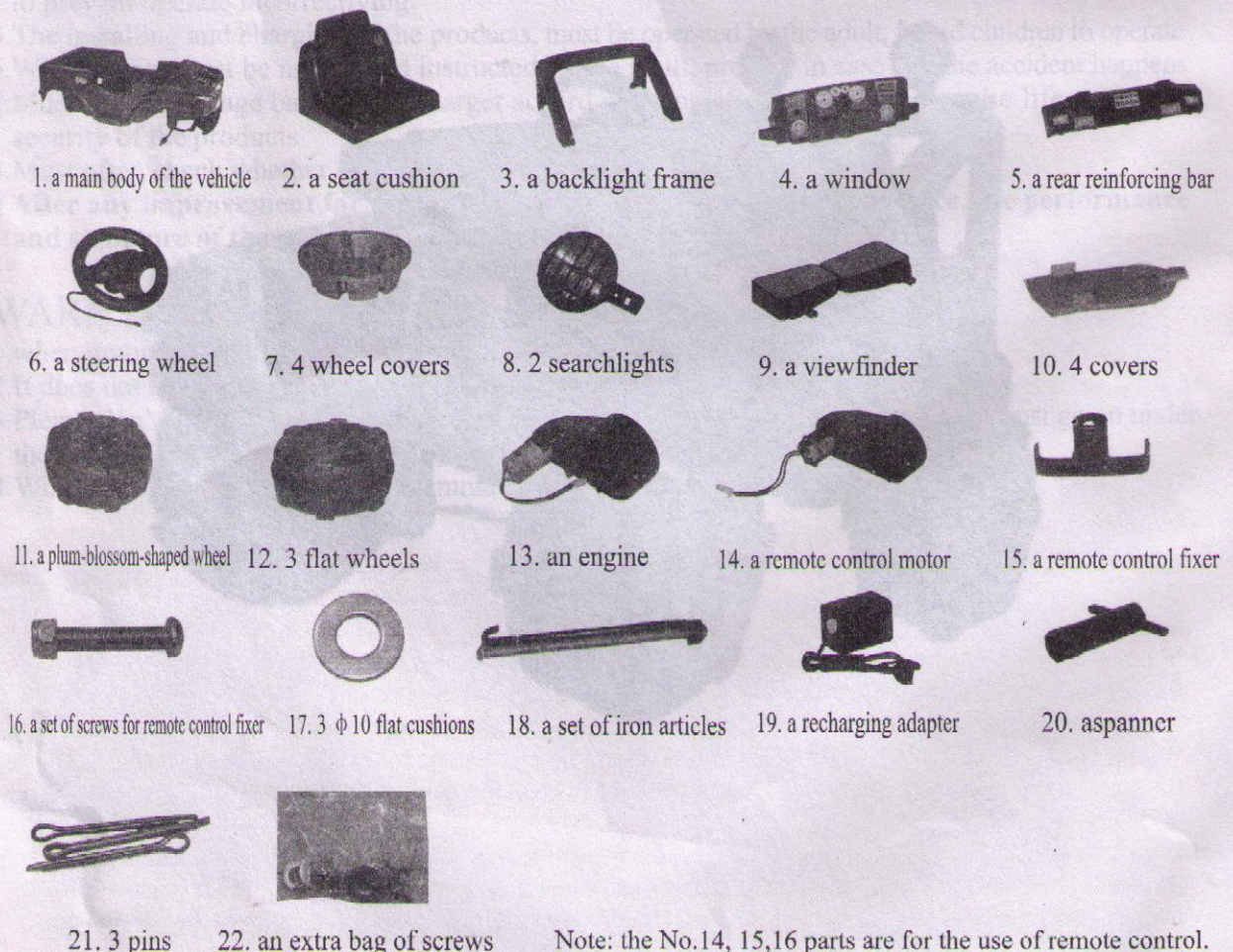
- 
1. a main body of the vehicle
 2. a seat cushion
 3. a backlight frame
 4. a window
 5. a rear reinforcing bar
 6. a steering wheel
 7. 4 wheel covers
 8. 2 searchlights
 9. a viewfinder
 10. 4 covers
 11. a plum-blossom-shaped wheel
 12. 3 flat wheels
 13. an engine
 14. a remote control motor
 15. a remote control fixer
 16. a set of screws for remote control fixer
 17. 3 ϕ 10 flat cushions
 18. a set of iron articles
 19. a recharging adapter
 20. a spanner
 21. 3 pins
 22. an extra bag of screws

Note: the No.14, 15,16 parts are for the use of remote control.

Disassemble chart.....

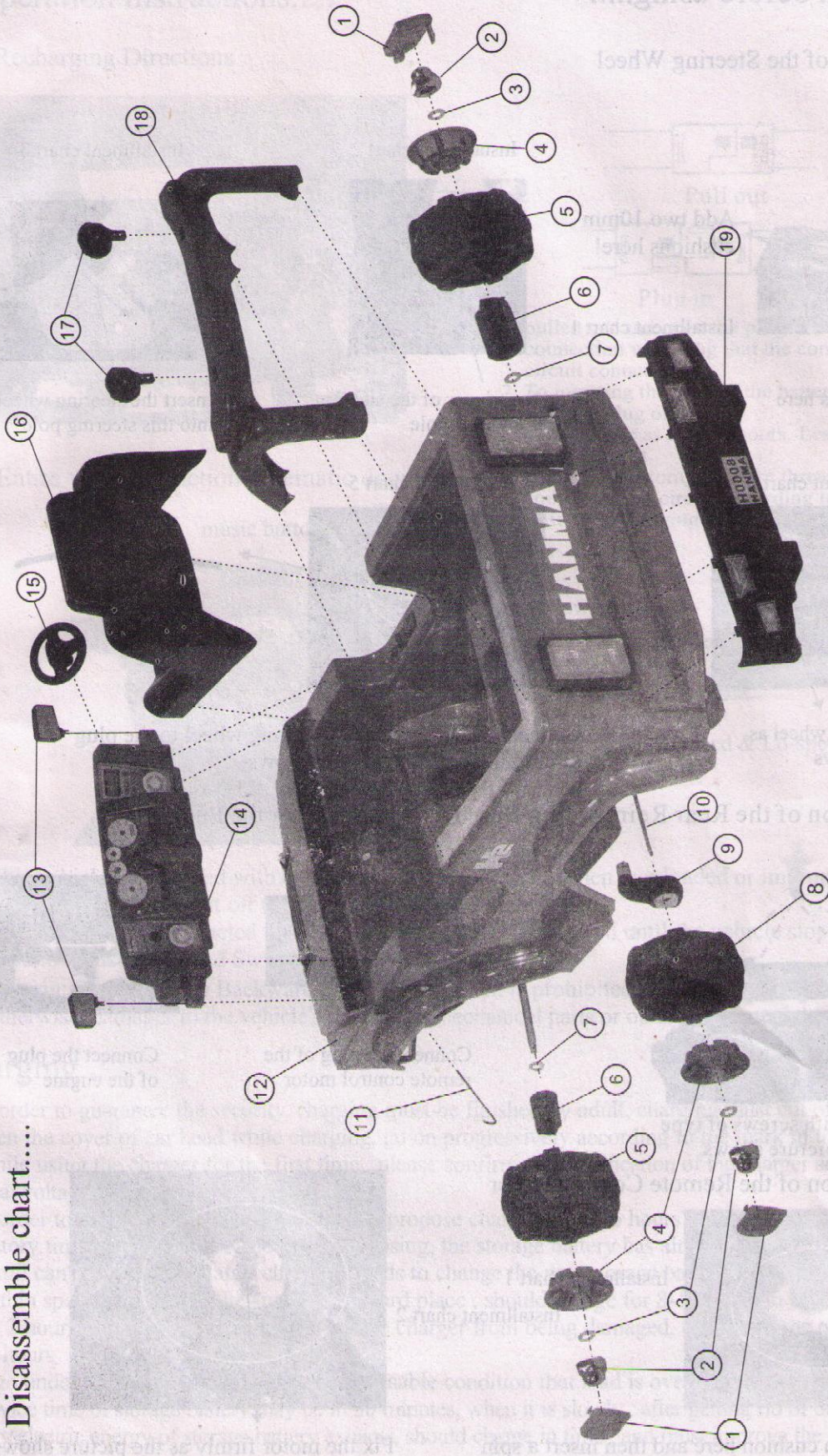

- 1. 4 covers
- 2. 4 10mm cushions
- 3. 4 flat wheels
- 4. 4 wheel covers
- 5. 3 12mm cushions
- 6. 3 axes ringers
- 7. 5 12mm cushions
- 8. a plum-blossom-shaped wheel
- 9. a rear axle
- 10. a steering pole
- 11. a steering wheel
- 12. a main body
- 13. a viewfinder
- 14. a meter panel
- 15. a steering wheel
- 16. a seat cushion
- 17. 2 searchlights
- 18. a backlight frame
- 19. a rear reinforcing bar

Installation before using.....

I. Installation of the Steering Wheel

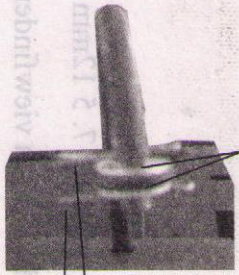

Add two 10mm cushions here!

Installment chart 1

Add two spins here

Installment chart 4

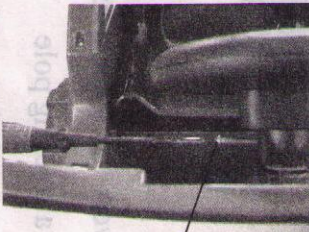

Fix the steering wheel as the picture shows

Installment chart 2

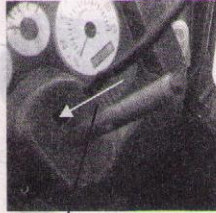

Plug the trigger of the steering wheel into this hole

Installment chart 3



Insert the steering wheel into this steering pole

Installment chart 5

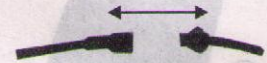
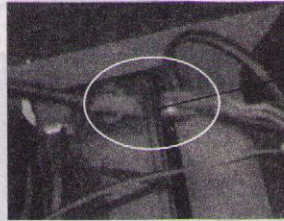

Connect the trigger of the steering wheel to the plug of circuit like as the picture shows

II. Installation of the Rear Reinforcing Bar III. Connecting of the Engine



Fix the Bar with screws of type 4×12 as the picture shows



Connect the plug of the remote control motor

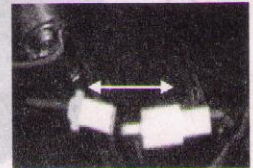

Connect the plug of the engine

IV. Installation of the Remote Control Motor

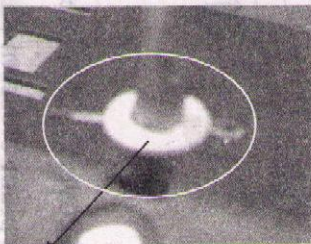

Installment chart 1

Add a 10mm cushion here and then insert a spin

Installment chart 2

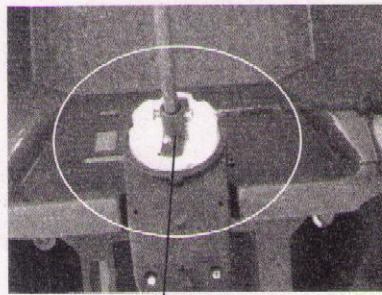

Fix the motor firmly as the picture shows

Operation instructions.....

I. Recharging Directions

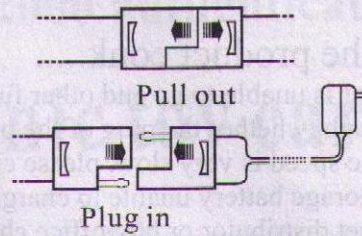
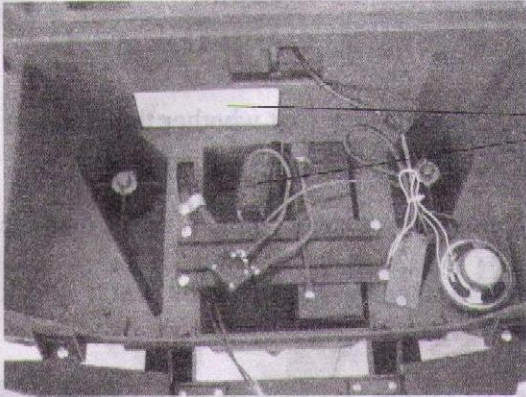

1. pulled out and open the plug of the battery connection with plug that the completed car circuit connects
2. To inserting the plug of the battery connection with the plug of charger
3. Charge time as 8 to 12 hours, Less than 20 hours at most
4. Connect the storage battery thread with completed car circuit according to the former state after charging and finishing

II. Entire vehicle function schematic drawing

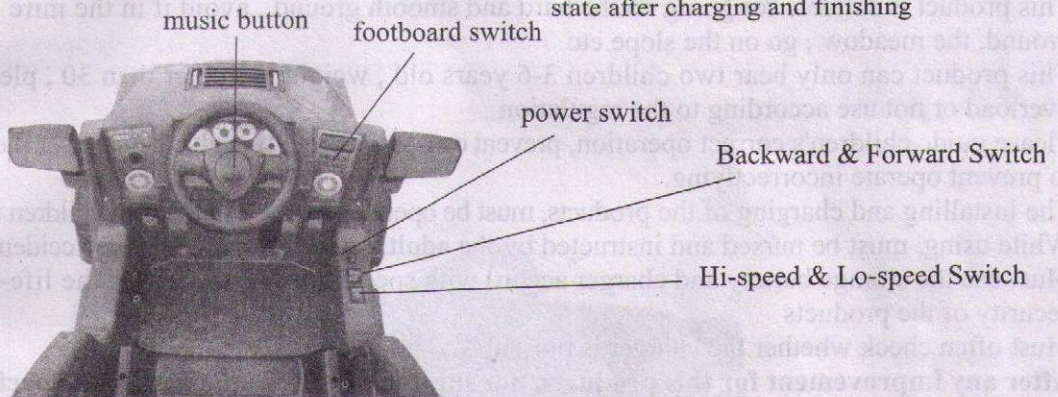

- III. This vehicle is equipped with an auto-reset safety device. When overloaded or improperly used, it will automatically cut off the power for 15 to 20 seconds.
- IV. Children must be instructed that the pedal must be fully released until the vehicle stops when they need to adjust the Speed Switch.
- V. Warning: Switching the Backward & Forward Switch is prohibited while the vehicle is running. Otherwise, damages to the vehicle's circuit and mechanical parts or other unexpected things will occur.

charging.....

1. In order to guarantee the security, charging must be finished by adult, charging must cut off the power, open the cover of car head while charging, go on progressively according to the mark in the car. Notice: While using the charger for the first time, please confirm the specification of the charger accord with the local voltage
2. In order to guarantee the voltage is steady, propose charging for 4-6 hours before using. If appear factory time get to exceed 3 months while using, the storage battery has already lost efficiency probably, if still can't use normally after charging needs to change the new storage battery
3. Within specified load, on the smooth and hard place, should charge for 8-10 hours in time after going for 2 hours normally, in order to prevent the charger from being damaged, charging time can't exceed 20 hours
4. If go under the road is not smooth or abominable condition that load is overweight, etc., the continuous service time of storage battery may be in 30 minutes, when it is slowly, after getting rid of other troubles, may electric energy of storage battery exhaust, should charge in time, and must improve the condition of going

5. After charging, the charger will be a little hot, is a normal response. If opposite, the charger, storage battery or the circuit has broken down
6. The products are not used for a long time, must fully charge first, charge every 3 months once, guarantee the life-span of the storage battery

While the product conk.....

1. As the car is unable to go and other function also invalid, please check first whether the power is put through, whether the plug of the power is damaged
2. When the speed is very slow, please charge in time
3. When Storage battery unable to charging, please check storage battery or charger, if it is damage, please get distributor or buy office change or buy
4. If there are other questions, please send the products back to retailer, we will do the best to check and repair for you, thanks

REMARKS:

1. This product is not means of transportation, forbid run it on the road, such dangerous places as the street or the slope, etc.
2. This product is suitable for going on the hard and smooth ground, avoid it in the mire, the sand ground, the meadow, go on the slope, etc
3. This product can only bear two children 3-6 years old, weight is lighter than 30, please don't overload or not use according to the regulation
4. Please guide children's correct operation, prevent causes the products to be damaged or met accident to prevent operate incorrectly.
5. The installing and charging of the products, must be operated by the adult, forbid children to operate
6. While using, must be nursed and instructed by the adult, prevent in case that the accident happens
7. Must use the storage battery and charger accord with specification, guarantee the life-span and security of the products
8. Must often check whether the charger is normal

*** After any improvement for this products, not supply explain or the notice, the performance and structure of the products are subject to material object**

WARNING

1. when not using, please cut off power, all switch press to " stop " or " imprison "
2. It does not accord with the fuse of our product specification that please don't use
3. Please don't change the structure of this product and circuit system by yourself. it must go on under the guidance of technical staff or by professional personnel to maintain
4. While charging, must far leave flammable articles, prevent fire from occurring